

GSL-BESS-418K



- GSL ENERGY provides a one-stop solution for business and large-scale energy facilities to save electricity bills, reduce the risk of energy price increases, generate additional benefits from renewable energy, and reduce its impact on the environment.
- GSL-BESS-418K is a modular ESS designed specifically for industrial and large-scale energy storage applications.
- The battery cell is the fundamental unit of the system. BMS includes C64 and BCU. BMS integrates data from battery cells, modules, and cabinets, and communicates with other devices.

01 INPUT & OUPUT

DC INPUT

DC OUTPUT

02 The battery cabinet contains

8 electrical boxes + a main control box + a cooling system + a fire protection system

03 Scenes



Factories



Shopping malls



Residential areas



Hospitals



Other locations

GSL-BESS-418K



Weight :3.5t

Battery Parameter

Item	Subitem	Parameters
Capacity	Rate Energy	418kWh
	Ah Capacity	628Ah
Pack Module	Cell Type	LiFePO4
	Series & Parallel	52S1P
Voltage	Rated Voltage	665.6V
	Voltage Range	582.4~748.8VDC
Current	Rated Char/disc current	157A
	Max Char/disc current	314A (Ta=25±3)
Rated Output Power	Rated	0.5P
	Maximum	1P
Operating Temperature	Charging	0~55 C
	Discharging	-20~60 C



System Parameter

Environment	Storage Humidity	RH ≤85%	No condensing
	Storage Temperature	-30~45 C	
	Altitude	≤2000m	
General Parameters	Size	1300W*1300D *2340H (mm)	
	Weight	3500kg	
	IP Level	IP55	
	Cooling Method	Liquid Cooling	
	Communication Interface	CAN, RS485, WIFI	
	Coolant	50% Ethylene glycol aqueous solution 50%	

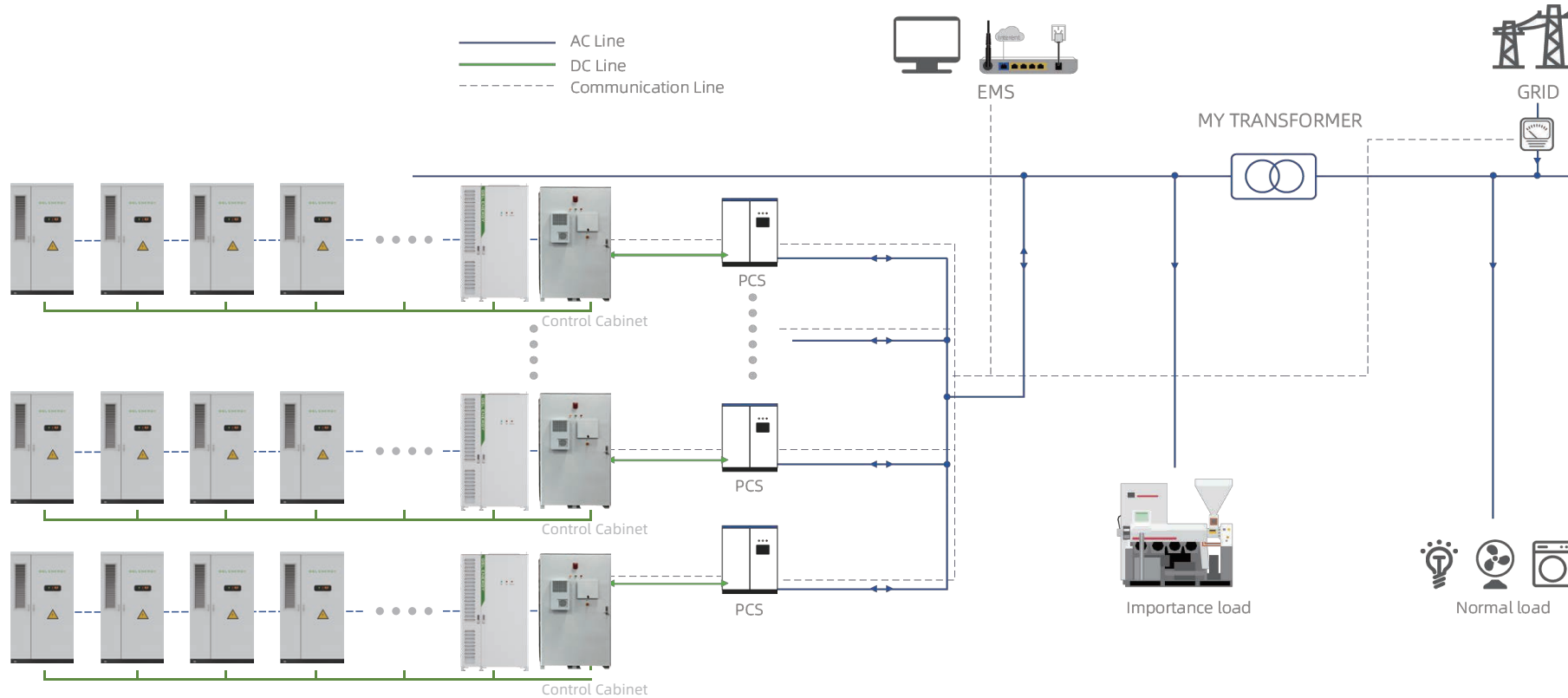

Standards and Certifications

UL1973、UL9540A、IEC/EN62619、IEC/EN63056、IEC/UL60730、IEC/EN61000、
FCC Part15、UN38.3



NO.	Scenarios	Rate	Configuration	DC Configuration	AC Configuration
1	C&I	0.5P	1.725MW/3.35MWh	10*418kWh cabinets + 1*combiner cabinet	One 1725KW PCS
2		0.25P/0.3P	1MW/3.35MWh	10*418kWh cabinets + 1*combiner cabinet	One 1200KW PCS
3	Public Utility	1P	10*418kWh cabinets + 1*combiner cabinet + 1*3950kW PCS		
4		0.5P	10*418kWh cabinets + 1*combiner cabinet + 1*1725kW PCS		
5		0.25P/0.3P	10*418kWh cabinets + 1*combiner cabinet + 1*1200kW PCS		

GSL-BESS-418K

Typical application scenarios/configurations, and site layout

- ① Each DC combiner cabinet supports 10 or less 372kWh cabinets;
- ② The following diagram shows the spatial layout of 9 integrated cabinets and 1 DC control cabinet.

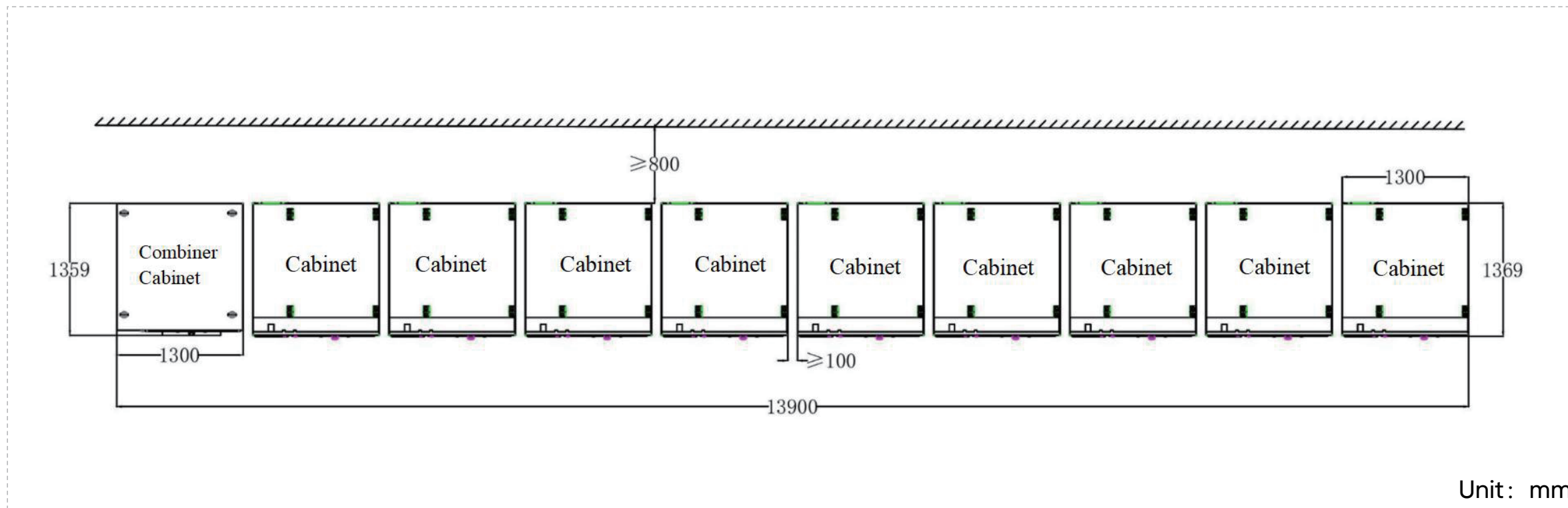

GSL-BESS-418K

Combiner Cabinet:

Set up a fire control host and one smoke detector inside the combiner cabinet, and set up an audible and visual alarm outside the cabinet.

Battery Cabinet:

Install smoke detectors, temperature detectors, and electric aerosol fire extinguishing devices (250g for single 372KWh ESS cabinet and 100g for single 215KWh ESS cabinet).

Connection:

The fire control host inside the combiner cabinet needs to be wired to the detectors and aerosol fire extinguishing devices inside the battery cabinet.

Working logic:

When the smoke and temperature detection signals are transmitted in real-time to the fire control host in the control cabinet, and when both smoke and temperature alarms are triggered simultaneously, the fire control host sends a signal to activate the aerosol fire extinguishing device and sound and light alarm in the cabinet, and receives a feedback signal that the aerosol fire extinguishing device has successfully started.

