

Solar Lithium Battery Energy Storage System

User Manual

Version: 1.0

LiFePO4 Battery 51.2V 314Ah 16kWh

Model No : GSL-W-A16K

For On / Off Hybrid Solar Storage System

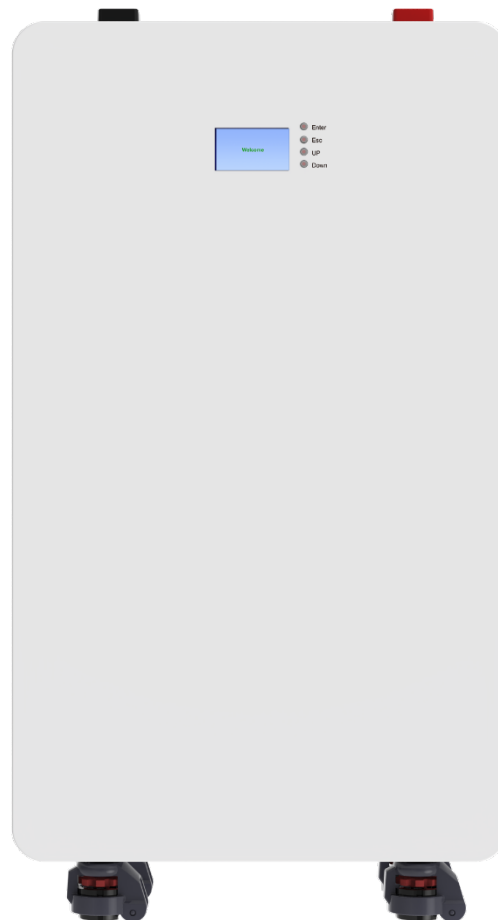

Contents

1. Safety Precautions	- 2 -
1.1 Before Connecting	- 2 -
1.2 During Operation	- 3 -
2. Battery Details	- 4 -
2.1 Battery Product Label	- 4 -
2.2 Dangerous Label	- 5 -
2.3 Battery Specifications	- 5 -
3. Introduction to The Battery	- 6 -
3.1 Key Features	- 6 -
3.2 Interface Introduction	- 7 -
3.3 SOC Indicator & Status Indicator Guides	- 10 -
3.4 Connectors	- 12 -
3.5 Wake Up Button	- 12 -
4.Safe Handling of LiFePO4 Battery Guide	- 13 -
4.1 Tools	- 13 -
4.2 Safety Gear	- 13 -
5.Installation	- 14 -
5.1 Standard Package List Items	- 14 -
5.2 Installation Location	- 15 -
5.3 Installing the Battery Pack	- 16 -
6.Use, Maintenance and Troubleshooting	- 25 -
6.1 Battery System Usage and Operation Instructions	- 25 -
6.2 Alarm Description and Processing	- 28 -

1. Safety Precautions

- It is very important and necessary to read the user manual carefully before installing or using the battery. Failure to follow any of the instructions or warnings in this document can result in electrical shock, serious injury, death, or may damage the battery and the whole system.
- If the battery is stored for a prolonged time, it is requirement that they are charged every three to six months, and the battery voltage should be kept above 3.27V.
- The battery needs to be recharged within 12 hours, after fully discharging.
- Do not expose cable outside.
- All battery terminals must be disconnected before maintenance.
- Do not use cleaning solvents to clean the battery.
- Do not expose the battery to flammable or harsh chemicals or vapors.
- Do not paint any part of the battery, include any internal or external components.
- Do not connect battery with PV solar wiring directly.
- Any foreign object is prohibited to be inserted into any part of the battery.
- Any warranty claims are excluded for direct or indirect damage due to items above.

1.1 Before Connecting

- After unpacking, please check the battery and packing list first, if the battery is damaged or spare parts are missing, please contact the dealer.
- Before installation, be sure to cut off the grid power and make sure the battery is in the turned-off mode;
- Wiring must be correct, do not mix-connect the positive and negative cables, and ensure no short circuit with the external device;
- It is prohibited to connect the battery with AC power directly;
- Please DO NOT connect battery in series;
- It is prohibited to connect the battery with different type of battery;
- Please make sure battery SOC and Voltage should be the same level before paralleling two more batteries together.
- Please ensure the electrical parameters of battery system are compatible to inverter;
- Keep the battery away from fire or water.

1.2 During Operation

- If the battery system needs to be moved or repaired, the power must be cut off first and the battery is completely shutdown;
- It is prohibited to connect the battery with different type of battery;
- It is prohibited to put the batteries working with faulty or incompatible inverter;
- In case of fire, only dry powder fire extinguisher can be used, liquid fire extinguishers are prohibited;
- Please do not open, repair or disassemble the battery. We do not undertake any consequences or related responsibility due to violation of safety operation or violating of design, production and equipment safety standards.

2. Battery Details

2.1 Battery Product Label

Solar Lithium Battery Energy Storage System

Battery Type	LiFePO4 Battery
Battery Model	GSL-W-A16K
Battery Power	16.08KWh
Battery Voltage	51.2V
Capacity of Battery	314Ah
Charge Voltage	56V
Discharge Voltage	46V
Max Charge Current	≤150A
Max Discharge Current	≤150A
Depth of Discharge	80% DOD
Display	LCD/LED
Communication	CANBUS/RS485
Degree of Protection	IP50

Manufacturing Date: YYYY/MM/DD







CAUTION		CAUTION	
	DO NOT PUT HANDS INTO SAFETY GUARD WHEN MACHINE IS WORKING.		VOLTAGE ALSO PRESENT WHEN MASTER SWITCH IS TURNED OFF.

 This battery product meets European directive requirements

 Read the user manual before using

 After the battery life is terminated, the battery can continue to be used after it recycled by the professional recycling organization and do not discard it at all

 The scrapped battery cannot be put into the garbage can and must be professionally recycled

Keep battery far from fire-easy flammable and explosive materials.
Be careful with your actions and be aware of dangers

2.2 Dangerous Label

WARNING AVERTISSEMENT



1. Do not disassemble or alter the battery in any way.
Ne démontez ni modifiez la batterie en aucune façon.
2. Do not use the battery for purposes not described in its documentation.
N'utilisez pas la batterie à des fins non décrites dans sa documentation.
3. Do not drop, strike, puncture, or step on the battery.
Ne laissez pas tomber, ne heurtez pas, ne percez pas et ne marchez pas sur la batterie.
4. In case of electrolyte leakage, keep leaked electrolyte away from contact with eyes or skin, immediately clean with water and seek help from a doctor.
En cas de fuite d'électrolyte, évitez tout contact de l'électrolyte qui fuit avec les yeux ou la peau, nettoyez immédiatement avec de l'eau et demandez de l'aide à un médecin.
5. Do not put the battery into a fire. Do not use it or leave it in a place near fire, heaters, or high temperature sources.
Ne mettez pas la batterie au feu. Ne l'utilisez pas et ne la laissez pas à proximité de feux, de radiateurs, ou de sources de températures élevées.
6. Do not submerge the battery in water, or expose it to moisture.
Ne plongez pas la batterie dans l'eau et ne l'exposez pas à l'humidité.
7. Do not allow the terminals to contact exposed wire or metal.
Ne laissez pas les bornes entrer en contact avec du fil ou du métal exposé.
8. The battery is heavy and can cause injury if not handled safely.
La batterie est lourde et peut provoquer des blessures si elle n'est pas manipulée en toute sécurité.
9. Keep out of reach of children or animals. Tenir hors de portée des enfants ou des animaux.

2.3 Battery Specifications

Battery Specifications	
Model No	GSL-W-A16K
<i>Nominal Parameters</i>	
Nominal Voltage	51.2V
Rated Capacity	314Ah
Energy	16.07kwh
Dimensions (L x W x D)	450*240*850mm /17.7*9.4*33.4 in
Weight	122kgs /268 lbs

Electrical Parameters	
Max. discharge voltage of battery	56VDC
End of discharge voltage of battery	46VDC
Maximum charge current of battery	200A
Maximum discharge current of battery	200A
Charging temperature range of battery	0-45°C
Discharge temperature range of battery	-20- 60°C
Number of cells in battery pack	16S1P
Lithium Battery Standard	IEC62619, CE-EM, UN38.3, MSDS
Enclosure protection rating	IP50

3.Introduction to The Battery

3.1 Key Features

- LiFePO4 composition provides exceptional safety and longevity
- High safety and reliability
- Consistent performance over wide temperature range
- Floor-mounted, convenient installation
- Integrated state-of-the-art BMS to manage and monitor battery information including voltage, current and temperature as well as balance cell charging/discharging rates

3.2 Interface Introduction

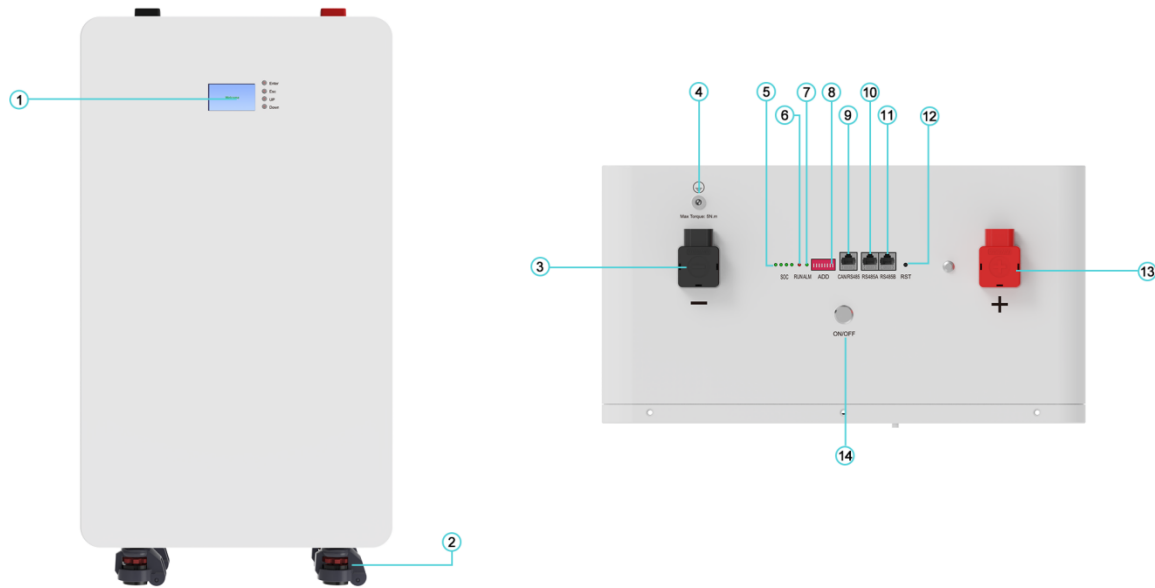

No.	Description	Silk-screen	Remark
1	Display Screen		
2	Rollers		
3	Battery Negative	-	
4	Ground Connection		
5	LED indicator	SOC	Remaining Battery Capacity
6	LED indicator	ALM	
7	LED indicator	RUN	Running State
8	DIP ADDRESS	ADD	8 PINS Number
9	CAN/RS485	CAN/RS485	Connecting battery to Inverter
10	RS485A/485B	RS485A/RS485B	Parallel function or connecting smart BMS software with computer
11	RS485A/485B	RS485A/RS485B	Parallel function or connecting smart BMS software with computer
12	RESET	RST	Restart function
13	Battery Positive	+	

14	Power Switch	ON/OFF	
----	--------------	--------	--

3.2.1 Communication interface

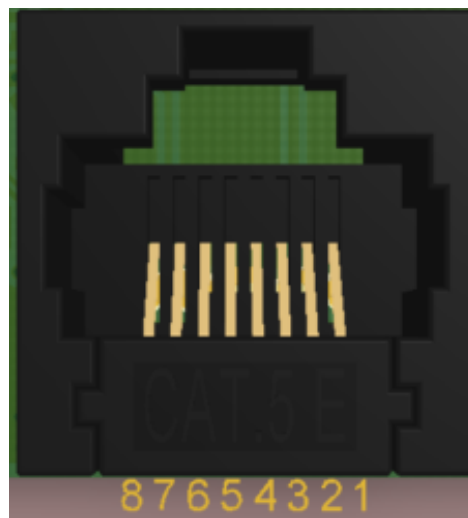
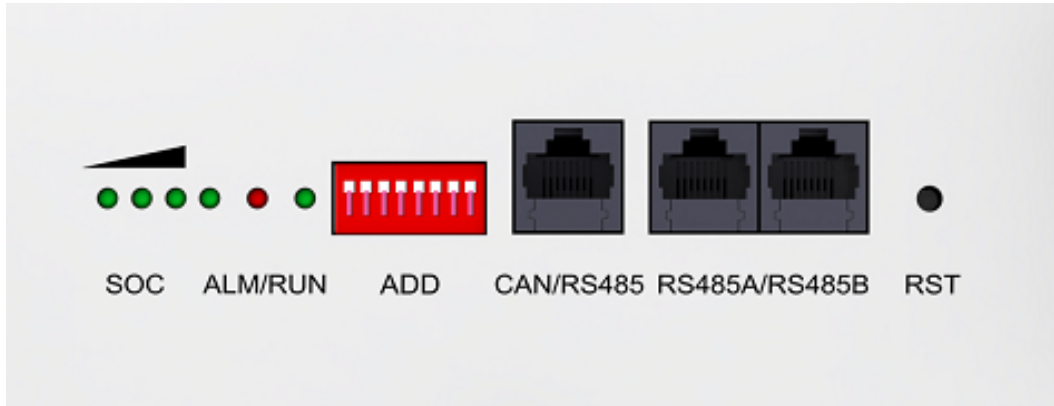

CAN&RS485

BMS and inverter communication connection

CAN - with 8P8C vertical RJ45 socket		RS485- with 8P8C vertical RJ45 socket	
RJ45Pins	Definition notes	RJ45Pins	Definition notes
4,	CANH	1、 8,	RS485-B
5,	CANL	2、 7,	RS485-A
		3、 6,	GND

3.2.2 BMS internal grid connection & monitoring

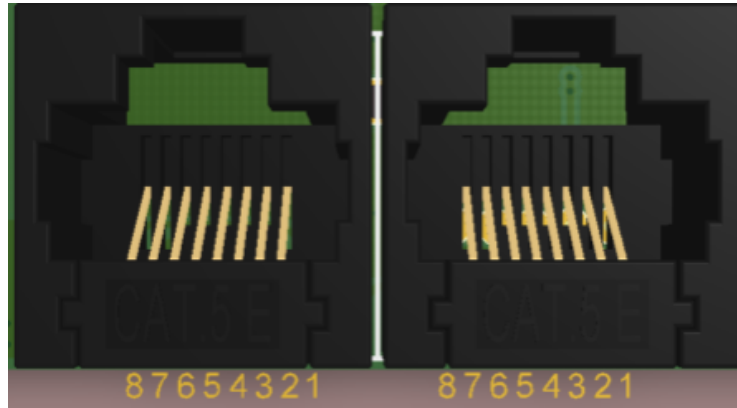

RS485-A/RS485-B

RS485_A - with 8P8C vertical RJ45 socket		RS485_B - with 8P8C vertical RJ45 socket	
RJ45 Pins	Definition notes	RJ45 Pins	Definition notes
1、 8、	RS485-B	1、 8、	RS485-B
2、 7、	RS485-A	2、 7、	RS485-A
3、 6、	GND	3、 6、	GND
4、 5、	NC	4、 5、	NC

3.2.3 Communication applications

- RS485 Stand-alone mode connection

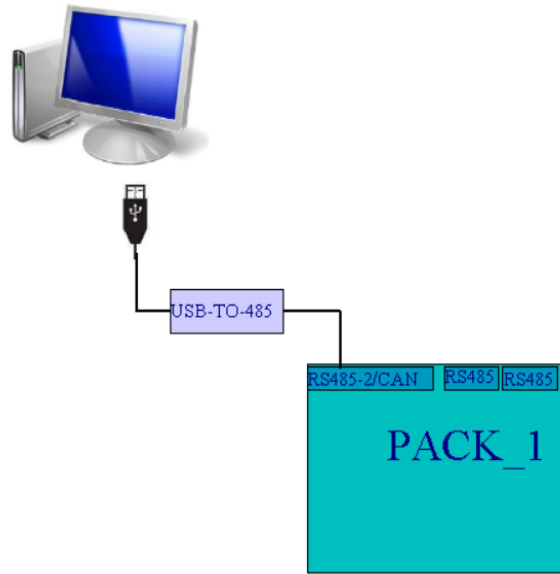

- RS485-A/B As master, CAN with inverter, 485-A/B as slave mode parallel communication

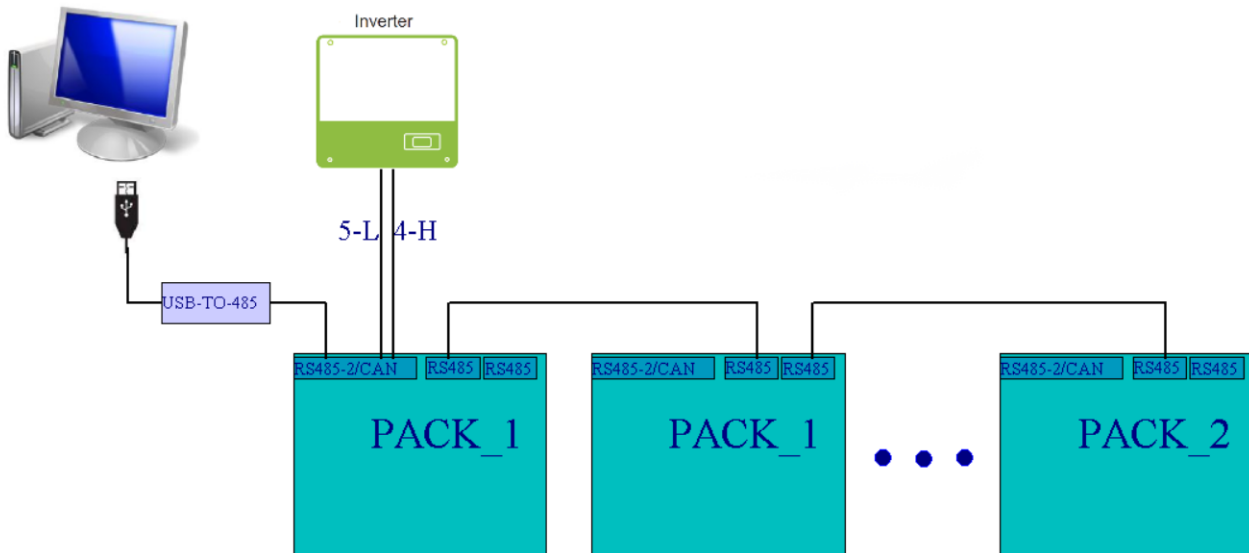

Note : Monitoring of battery system performance is achieved via inverter monitoring portal/app

3.3 SOC Indicator & Status Indicator Guides

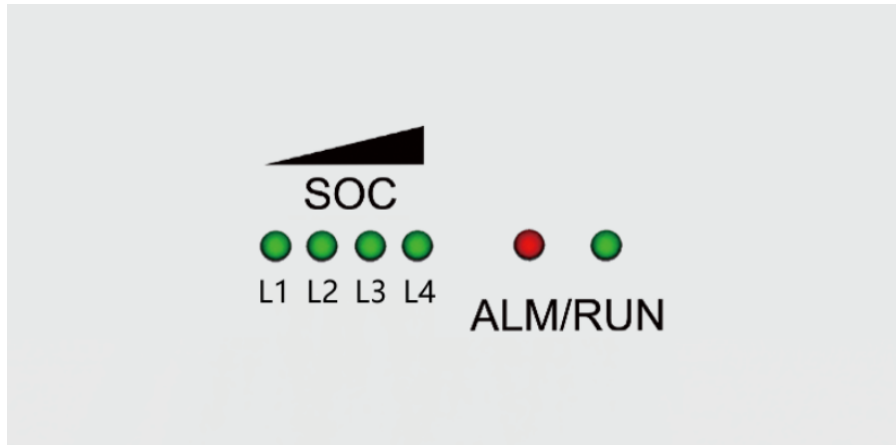







Chart 1 Battery Status

●	●	●	●	●	●
SOC				ALARM	RUN

Chart 2 Battery Capacity

Capacity		L1	L2	L3	L4
LED Indicator		●	●	●	●
SOC	0~25%	ON	OFF	OFF	OFF
	26~50%	ON	ON	OFF	OFF
	51~75%	ON	ON	ON	OFF
	76~100%	ON	ON	ON	ON
RUN Status ●		ON			

Chart 3 Battery Status

Status	RUN	ALM	Capacity LED			
						
Normal	Flash	Off	0-25%	26-50%	51-75%	76-100%
warning	Flash	Flash	0-25%	26-50%	51-75%	76-100%
Fault	Off	On	Display fault type			
Protection	Flash	On	Display protection type			

3.4 Connectors

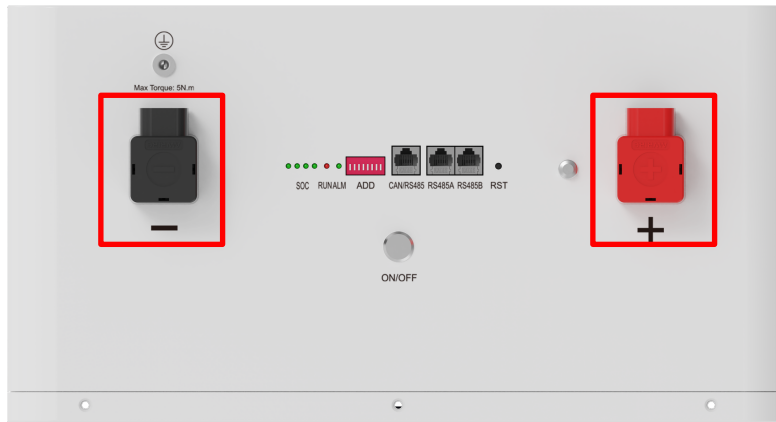

- A. Charge / Discharge connectors: to connect the positive pole (+) and negative pole (-) from the battery to the inverter via DC legislator.
- B. Can bus/485 active communication port between battery and inverter.
- C. USB to RS485: to get dynamic monitoring data of the battery from upper computer.
- D. Address: Reserved Address portal for multiple parallel connections.

3.5 Wake Up Button

- Battery On: When battery is shut down, press this RST button for 3 seconds. It is activated when the LED lights on.

- Battery off: When battery is activated, press this button :
 1. release the button when the LED lights don not finish flickering from lowest capacity indicator to RUN light,then the battery will shut down;
 2. when the LED lights flicker from lowest capacity indicator to RUN light and all lights are on, the battery will reset.

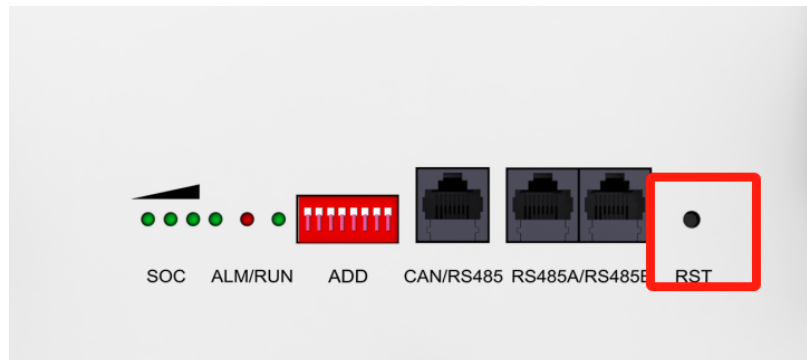

4.Safe Handling of LiFePO4 Battery Guide

4.1 Tools

The following tools are required to install the battery pack:



Wire Cutter



Crimping Modular



Screw Driver

NOTE

- Use properly insulated tools to prevent accidental electric shock or short circuits.
- If insulated tools are not available, cover the entire exposed metal surfaces of the available tools, except their tips, with electrical tape.

4.2 Safety Gear

It is recommended to wear the following safety gear when dealing with the battery pack:



Insulated Gloves



Safety Goggles







Safety Shoes

5. Installation

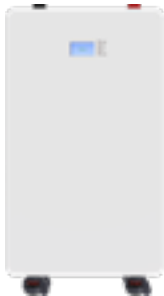
5.1 Standard Package List Items

Thoroughly inspect the packaging upon receipt of goods. If there is any item missing or if there is any damage to the external packaging or to the unit itself upon unpacking, please contact us immediately.

NO.	Item	Quantity	Specification
1	Battery Pack 	1 PC	16kWh
2	Power Cable	1 SET	1AWG Black , Red L: 1.0 meter

			Push-In Standard+ M10 Arterial
3	Communication Cable 	1 PC	Battery can bus port to Inverter can bus port L: 2.0 meter
4	Parallel Com Cable 	1 PC	Battery com port to Battery com port for parallel 16pcs at max L: 1.0 meter
5	Ground Cable 	1PC	Connect to the grounding point of the modules

5.2 Installation Location

Make sure that the installation location meets the following conditions:

- The installation site must be suitable for the size and weight of the battery.
- Must be installed on a firm surface to sustain the weight of battery.
- There are no flammable or explosive materials in proximity.
- The ambient temperature is within the range from 0°C to 45°C.
- The temperature and humidity is maintained at a constant level.
- There is minimal dust and dirt in the area.
- Installation must be vertical or tilted backwards by maximum 15° - avoid forward or side way stilt.

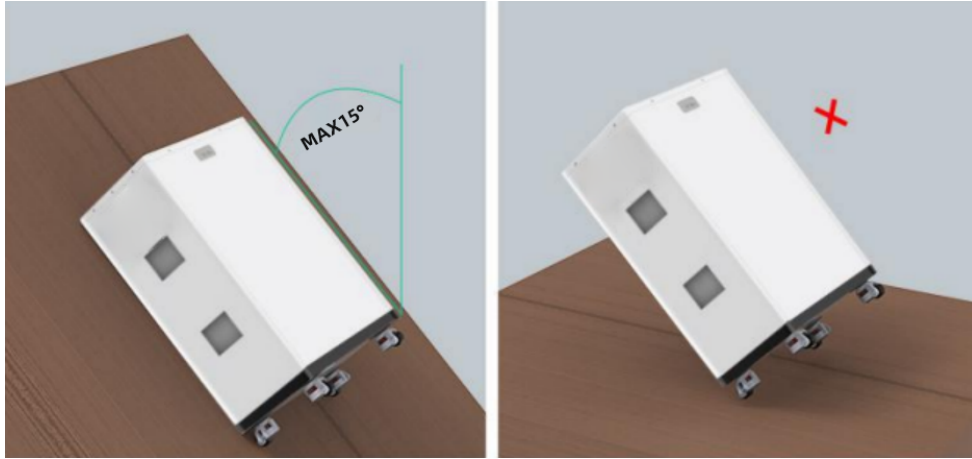

CAUTION

If the ambient temperature is outside the operating range, the battery pack stops operating to protect itself. The optimal temperature range for the battery pack to operate is 0°C to 45°C. Frequent exposure to harsh temperatures may deteriorate the performance and life of the battery pack.

5.3 Installing the Battery Pack

5.3.1 Mechanical installation

- 1, The ground at the installation site should be flat and have sufficient load-bearing capacity.
- 2, After placing the battery, please lock the wheels (rotate the handle counterclockwise to make the base tightly attached to the ground)

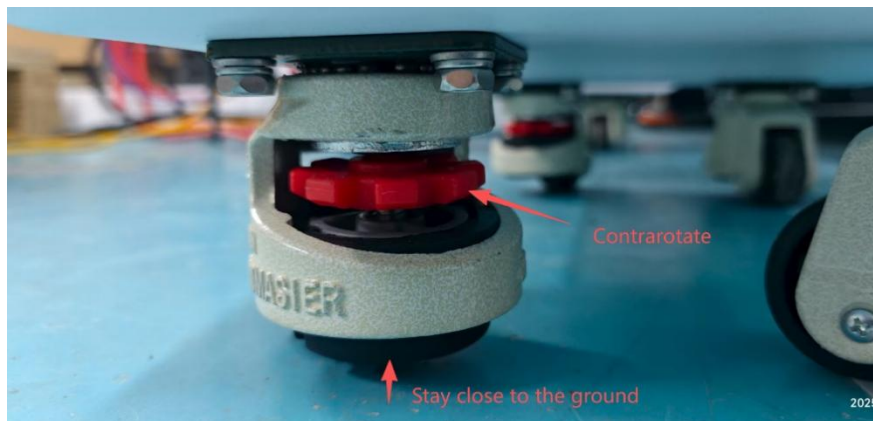

5.3.2 Connect the battery to the ground cable

The Ground cable has been provided by factory manufacturer. The bolt locking torque is 5 NM.

Install a grounding cable to the grounding point of the modules.



Grounding cable:

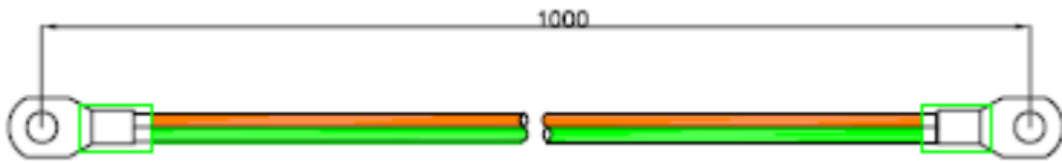

5.3.3 Inverter connection

1, When running independently, please set the jumpers to 00000000.

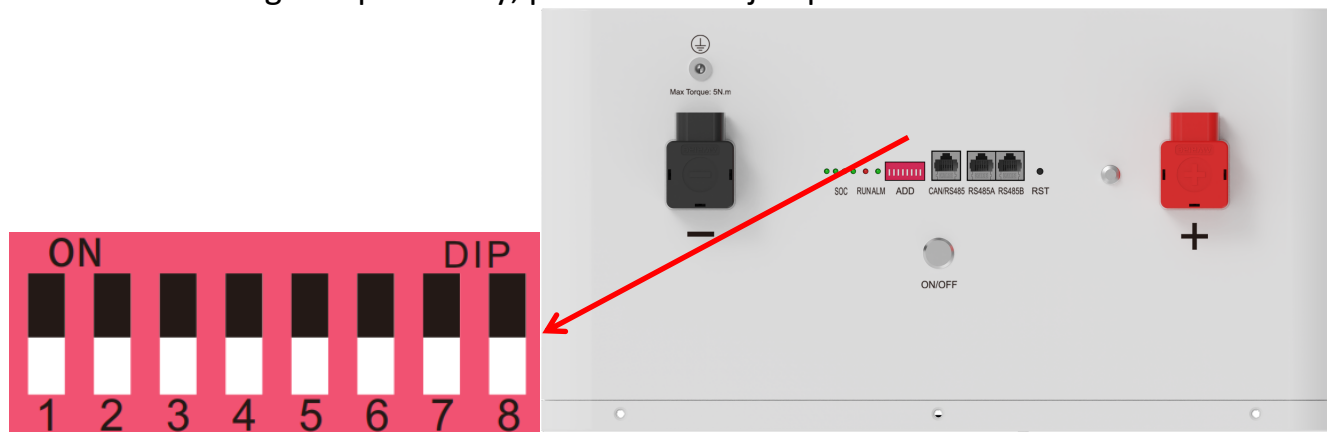

2, If the batteries need to be connected in parallel, please set the jumper switch as shown in the diagram.

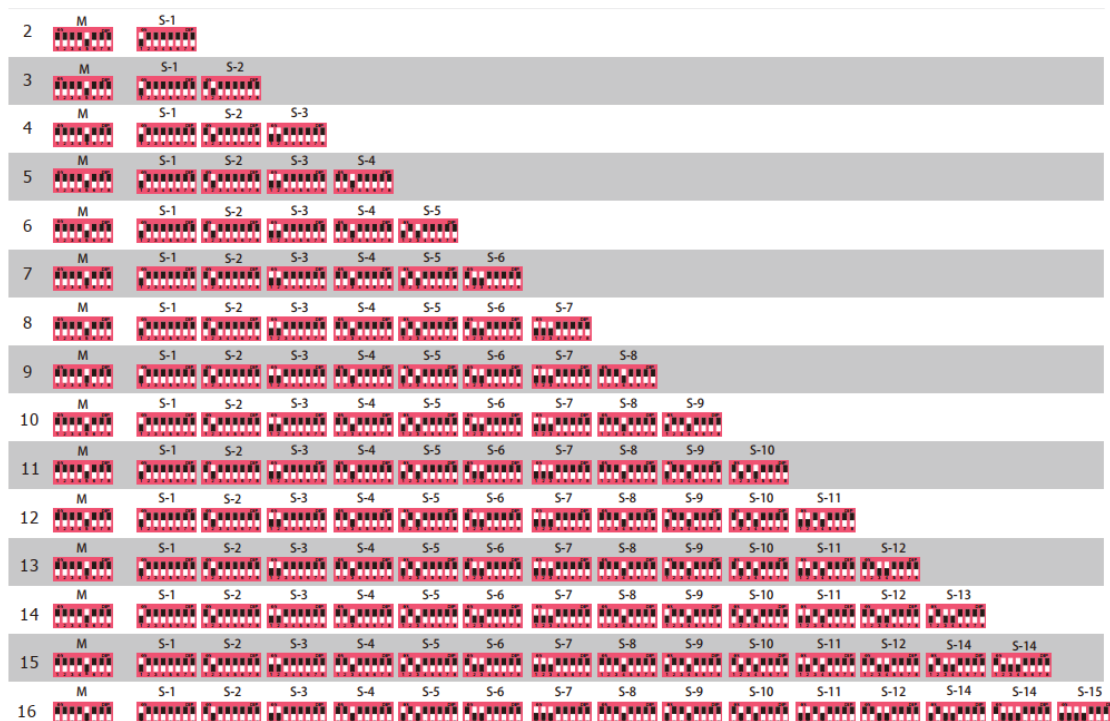

5.3.4 How to connect inverter

The battery is connected to the inverter, and it is required to use the dedicated power cable and communication cable (as accessories shipped with the cargo, the standard

communication cable is a standard network cable. the standard communication cable。 .

Keep the battery system at power off state, connect the power cable to the interface on the input side of the inverter first, and then connect the power cable to the interface on the battery side.

Power cables sets :

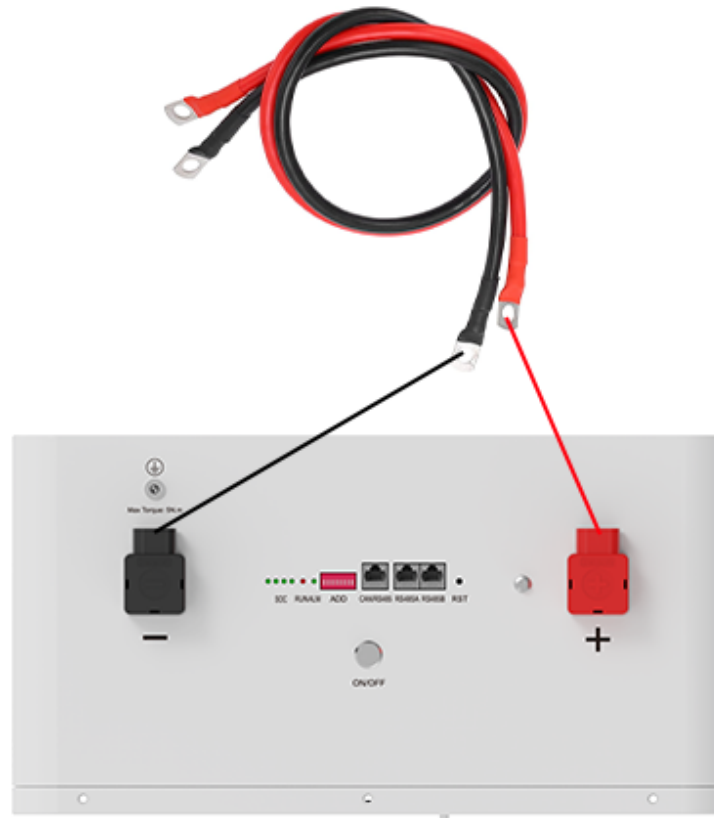

5.3.5 Connection of communication interface

Connect the CAN IN port of the battery to the CAN or RS485 communication interface of the inverter using the RJ45 cable.

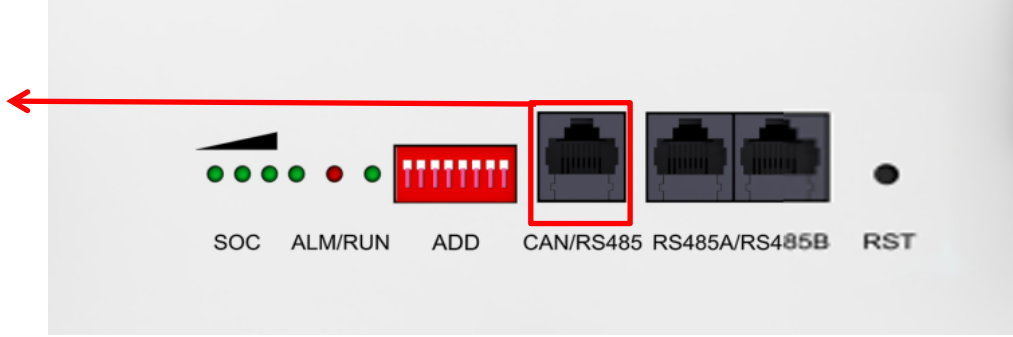

RJ45 Pinout T-568B

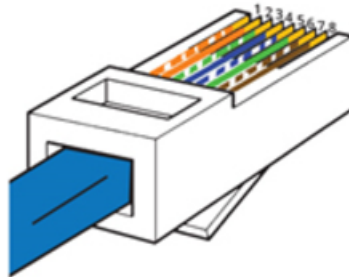

PIN Definition

Foot Position	Color	Definition
PIN 1	White Orange	RS485-B1
PIN 2	Orange	RS485-A1
PIN 3	White Green	GND
PIN 4	Blue	CAN-H
PIN 5	White Blue	CAN-L
PIN 6	Green	GND
PIN 7	White Brown	RS485-A2
PIN 8	Brown	RS485-B2

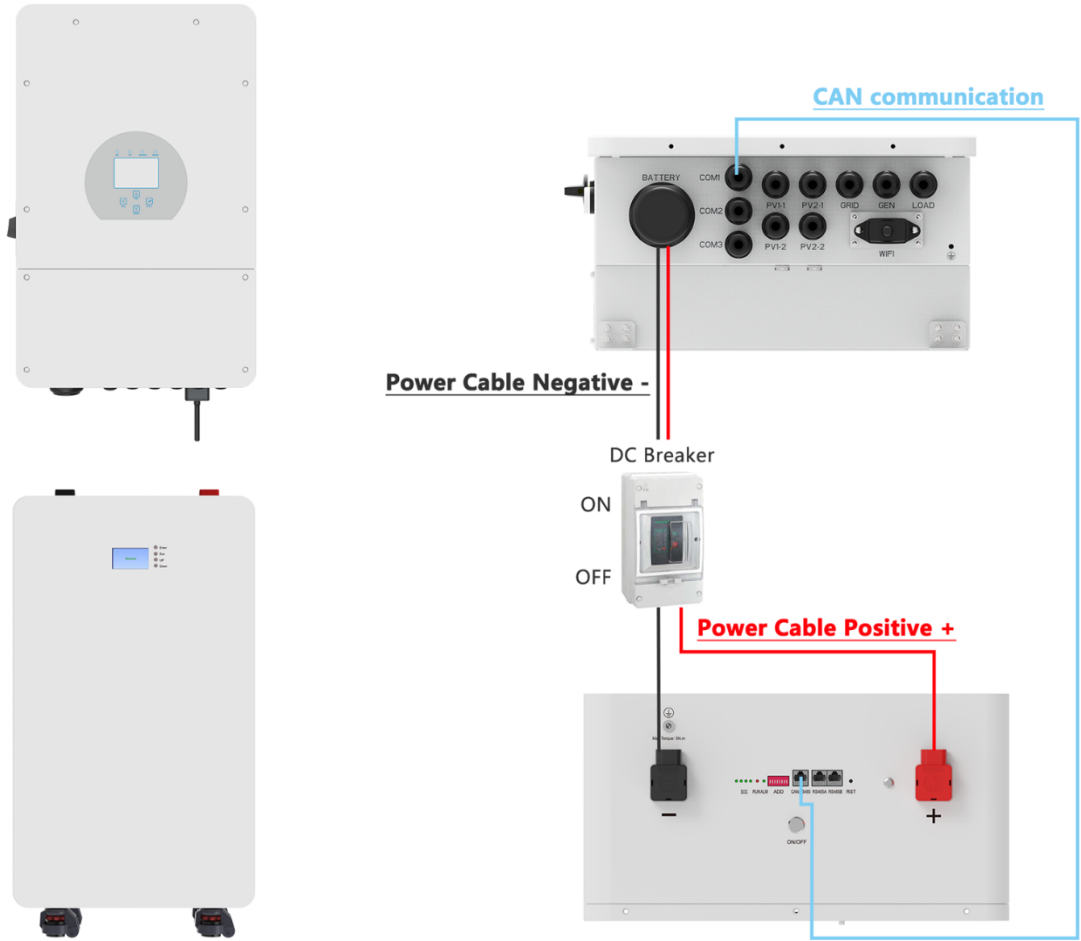

5.3.6 Parallel use of battery

When the system is used in parallel, it supports up to 16pcs wall batteries in parallel. According to the number of parallel system (**Take 3 batteries in parallel as an example**), it needs to use: **Power cable × 3 pairs, Battery-Inverter communication cable × 1PCS, Battery-Battery communication cable × 2PCS, Distribution box × 1PCS**).The over-current capacity of the distribution box should be much higher than the maximum nominal current value when the load is running

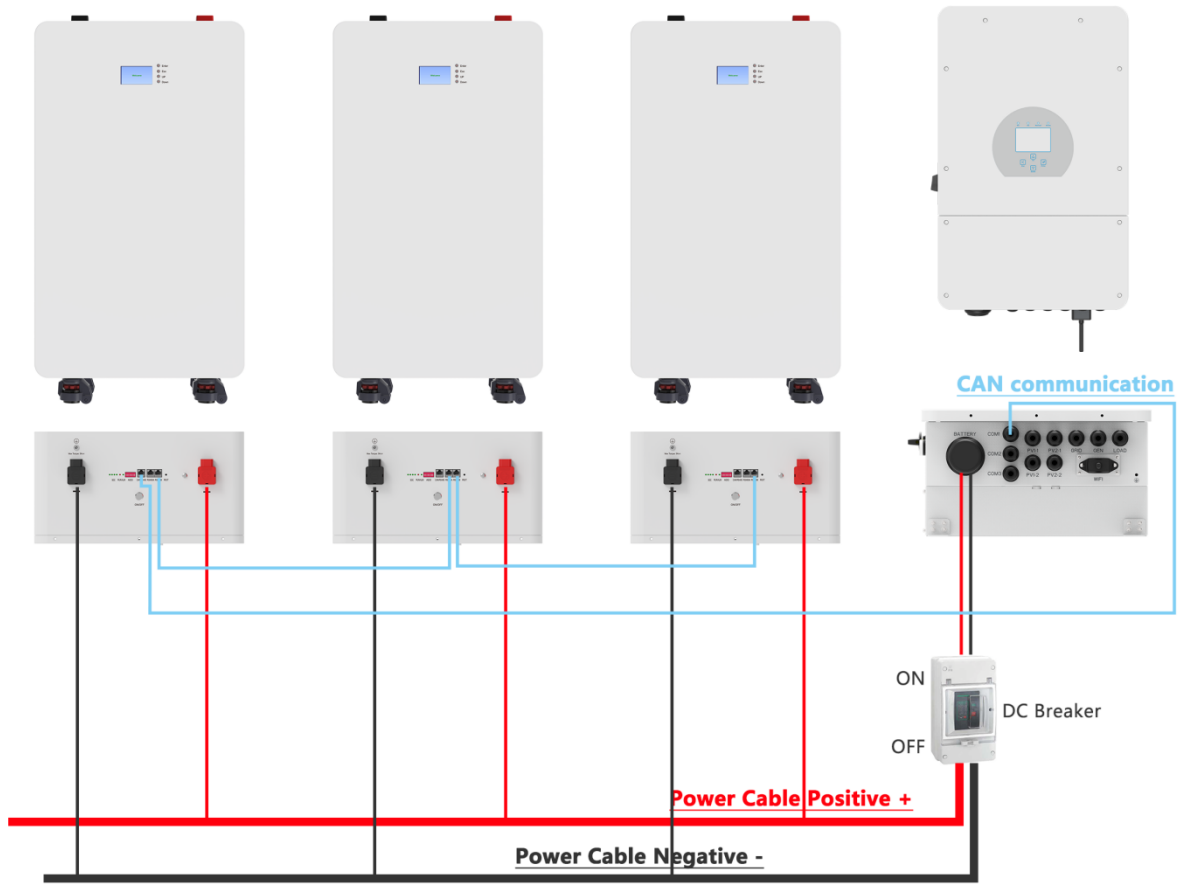

PINOUT of System Parallel communication cable

PINOUT of Battery-Battery communication cable diagram shown as below:

Communication cable for battery parallel connection

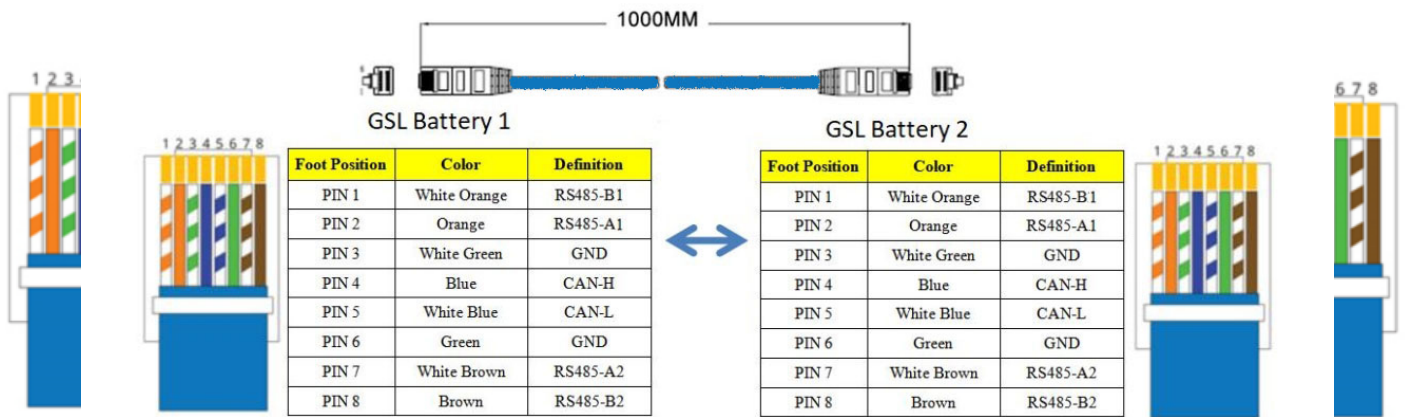

Modifying the power cables to insert an over-current protection and isolation device between parallel batteries will not void product warranty.

- Before connection, the positive and negative pole of the inverter input interface and the battery output interface should be confirmed.
- The red power line is connected to the positive pole and the black power line is connected to negative pole.
- Before connection, it is necessary to confirm the charge and discharge parameters of inverter interface.
- Voltage and current should meet the requirements of Table 2-2 battery performance parameters.
Note: For more information of matching inverter brands, please subject to the latest document
- How to judge that the communication between the product is normal:
 - 1) If there is communication between the inverter and battery system, it can be judged by the maximum charge and discharge current value on the inverter sent by the battery.

$$\frac{\text{(The maximum charge and discharge current value display on the inverter)}}{\text{(The maximum charge and discharge current value of one battery module)}} = \text{number of modules}$$

A. If the equation holds after calculation, it means communication between the GSL battery is normal.

● Table 3-5 Battery& Inverter power matching table

Equipment Use	Charging a) The battery's long-term continuous charging current should be $\leq 0.5C$ b) If the battery remaining capacity is empty, please charge it within 48 hours after the battery is empty.
	Discharging c) The long-term continuous discharge current of the battery should be $\leq 0.5C$ d) The recommend maximum depth of discharge (DOD)of Battery PACK is no more than 85%.

6. Use, Maintenance and Troubleshooting

6.1 Battery System Usage and Operation Instructions

After completing the electrical installation, follow the instruction below to start the battery system.

1) Power on

Step 1. Before turning on the battery, please make sure the DC breaker between battery and inverter is on "OFF" position.

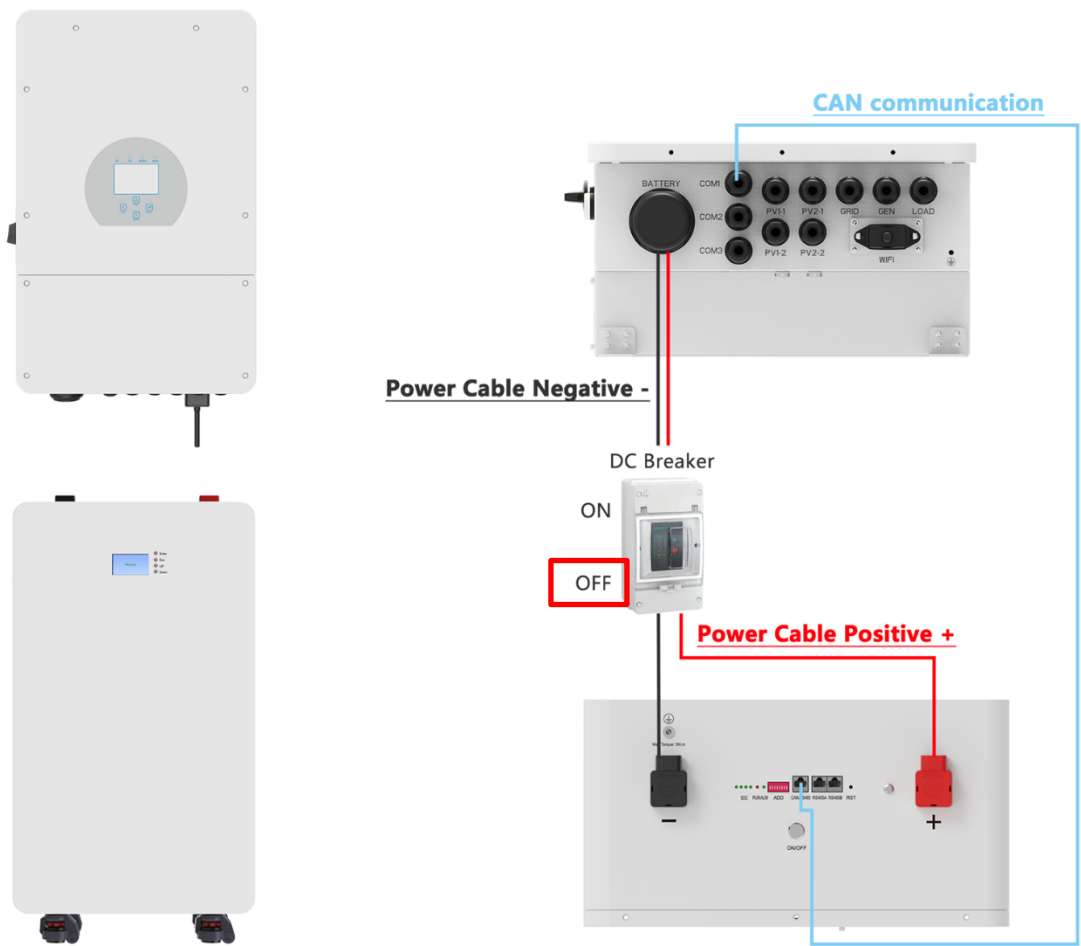

- Make sure battery positive and negative connect DC breaker +/- port .
- Red cable is for positive side; Black cable is for negative side.
- Make sure C oms cable connects inverter CAN port correctly.
- Make sure all the installation and operation must follow up local electric standard.

Step 2. Turn on Battery DC Switch , then LCD and LED will be flash at once, BMS is activated.

Customer can check battery SOC, Voltage state on LCD.



Step 3. Pull DC breaker to “ON” position on battery and outside DC breaker, then system can begin to work.

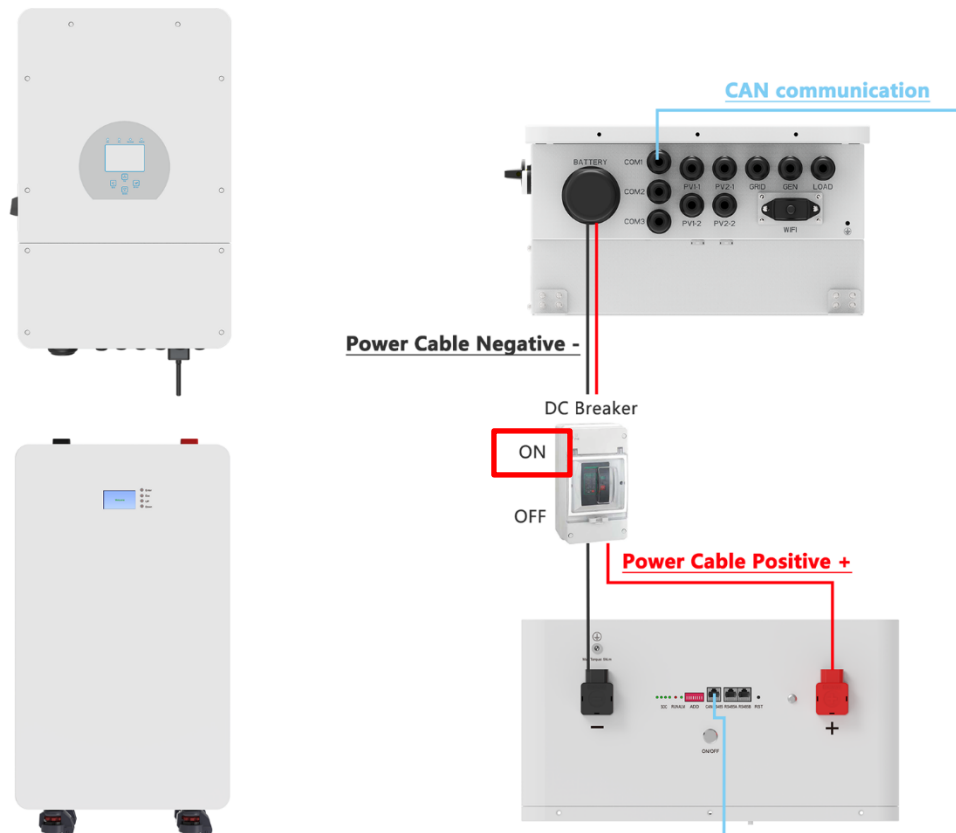

2) Power off

Step 1. Pull down DC breaker switch on "OFF" position.

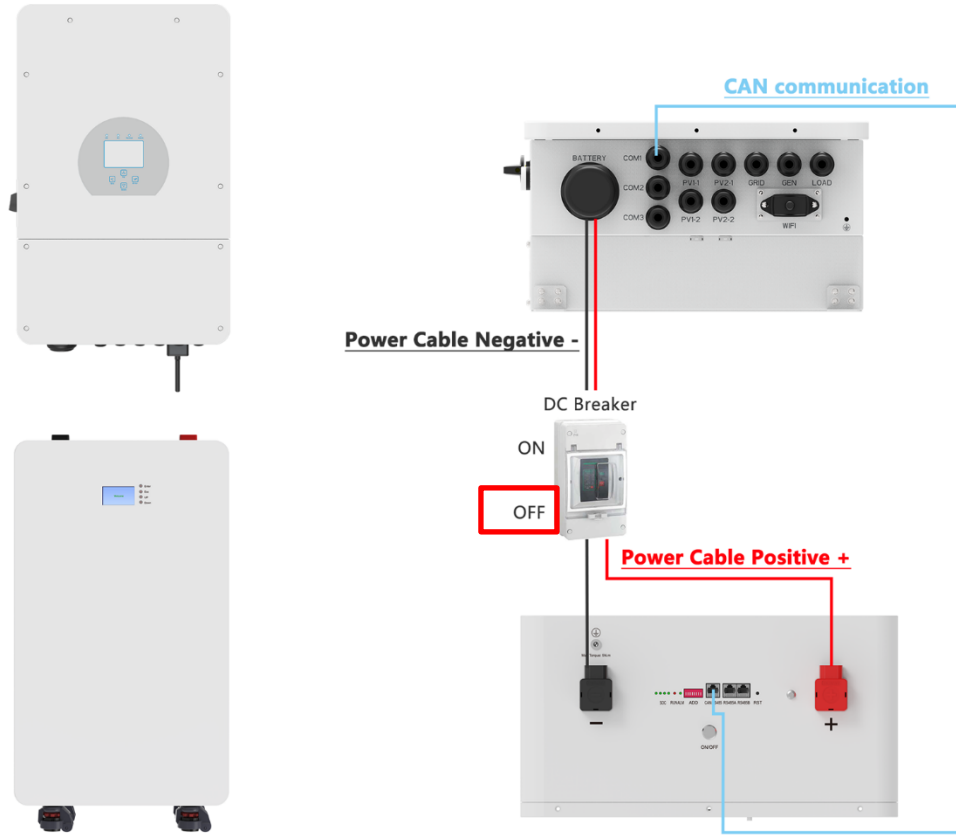

Step 2. Turn off Power switch to shut down BMS, LCD, LED finally.





Caution

- After pressing the power button, if the battery status indicator lights shows abnormally, please refer to the "6.2 Alarm description and processing". If the failure cannot be eliminated, please contact the retailer timely.
- Use a voltmeter to measure whether the voltage across the BAT + / BAT- terminals of the inverter is higher than 44.8V, and check whether the voltage polarity is consistent with the input polarity of the inverter. If the voltage across the terminals BAT + / BAT- of the inverter is higher than 44.8V, which means the battery has begun to work normally.
- After confirm the battery output voltage and polarity are correct, turn on the inverter, then turn on the circuit breaker switch.
- Check whether the indicator light for the inverter and the battery connection (the communication indicator and the battery access status indicator) is in normal condition. If normal, the connection between the battery and the inverter is completed. If the indicator light shows abnormal, please check the inverter manual or contact the local dealer.

6.2 Alarm Description and Processing

When protection mode is activated or system failure occurred, the LED indicator on the front panel will alarm, through net management can query specific alarm class and take appropriate action.

6.2.1 Alarm and countermeasure for affecting system output

If there are any abnormalities affecting the output, such as battery cell in the battery module occurs over-current protection during charge/discharge, under-voltage protection, and temperature protection, in the system, please deal with them according to Table 6-1.

Table 6-1 Main alarm and Protection

State	Alarm category	Alarm indication	Processing
Charge State	Over-current when charging	RED light flashing	Reduce the charging current below the rated value.
	High temp protection	RED light flashing	Stop charging and find out the cause of the trouble.

Discharge State	Over-current protection when discharge	RED light flashing	Stop discharge and reduce discharge current below rated value.
	High temp protection when discharge	RED light Flash in	Stop discharging and find out the cause of the trouble.
	Over-discharged protection	RED light flashing	Start charging.
	Low voltage alarm	Yellow light on	Start charging.

6.2.2 Alarm and countermeasure for non-affecting system output

If a low SOC alarm occurs, the battery system also issues a corresponding alarm signal. Maintainer should check the equipment according to the prompt information, determine the type and location of the fault, and take corresponding countermeasures to ensure that the system is in the best working condition to avoid affecting the system output. The phenomena and countermeasures are shown in Table 6-2.

Table 6-2 Minor alarm

Alert category	Alarm indication	Countermeasure
0<SOC<10%	System working status: RED light is always on	Stop discharge, and charge the battery system in time

6.2.3 Analysis and treatment of common faults

Table 6-3

Item	Fault phenomenon	Reason analysis	Solution
1	The indicator does not respond after power on the system	Make sure press and hold the power switch (Reset switch) for 3s.	Check the power switch

2	No DC output after power on the system	Check if the DC breaker is turned on	Check the status of the DC circuit breaker on the side of cabinet
3	No DC output and red light	Battery voltage is too low	Charging the battery system
4	The battery cannot be fully charged	Charging voltage is too low	Adjust charging voltage within 56V~57.6V range
5	The power cable sparks once power on and ALM indicated Red light on	Power connection short-circuit	Turn off the battery, check the cause of the short circuit

If you need any technical help or have any question, please contact the dealer in time.